

15T - SERIES

T3/DS3/E3/STS-1 TRANSFORMERS Designed for T3, DS3 and STS-1 Interfaces

FEATURES

- Return loss meets requirements
- Fast rise time compatible with standards
- Through hole and surface mount packages available
- Models with 1500Vrms isolation and 3000Vrms reinforced insulation per BABT EN41003/EN60950



TEST CONDITIONS

- Inductance 100KHZ/100mV
- Leakage Inductance 100KHZ/100mV
- Interwinding Capacitance 100KHZ/100mV

ELECTRICAL SPECIFICATIONS @25°C

Part Number	Turns Ratio (±2%)	OCL. Primary uH (MIN)	OCL at -40°C (uH) MIN	LL (uH) MAX	CW/W (pF) MAX	Isolation Voltage (Vrms) MIN	Package Schematic	Primary Pins
15T-3502TB	1:2CT	35	20	0.12	10	1500	T/B SMT	2-6
15T-4501TA	1:1	45	30	0.12	13	1500	T/A SMT	2-6
15T-4001QA	1:1	40	30	0.12	13	1500	Q/A THT	2-6
15T-3502QB	1:2CT	35	20	0.12	10	1500	Q/B THT	2-6
15T-1513QB	1:4CT	150	-	0.30	15	1500	Q/B THT	2-6
15T-5004LC	1:1.73CT	50	-	0.10	12	1500	L/C THT	4-6
15T-4001LE	1:1	40	-	0.10	10	1500	L/E THT	4-6
15T-4001SE	1:1	40	-	0.10	10	1500	S/E SMT	4-6
15T-1902SC	1:2CT	19	-	0.06	10	1500	S/C SMT	4-6
15T-1902LC	1:2CT	19	-	0.06	10	1500	L/C THT	4-6
15T-4001HA	1:1	40	-	0.10	5	3000	H/A THT	1-5
15T-1902HD	1:2CT	19	-	0.06	10	3000	H/D THT	1-5

ELECTRICAL SPECIFICATIONS @25°C—Operating Temperature -40°C to +85°C

Part Number	Turns Ratio (±2%)	OCL. Primary (uH) MIN	OCL at -40°C (uH) MIN	LL (uH) MAX	CW/W (pF) MAX	Isolation Voltage (Vrms) MIN	Package Schematic	Primary Pins
15T-1011XE	1:1	100	40	0.110	10	1500	X/E SMT	1-3
15T-4002XC	1:2CT	40	19	0.110	12	1500	X/C SMT	4-6
15T-1011SE	1:1	100	40	0.110	10	1500	S/E SMT	4-6
15T-4002SC	1:2CT	40	19	0.110	12	1500	S/C SMT	4-6
15T-4003XF	1CT:1CT	40	19	0.100	10	1500	X/F SMT	1-3
15T-4004XC	1:1.155CT	40	20	0.150	12	1500	X/C SMT	4-6

ELECTRICAL SPECIFICATIONS @25°C

Part Number	Turns Ratio (±5%)	OCL Primary (Mh) MIN	CW/W (pF) MAX	LL (uH) MAX	DCR Pri (Ω) MAX	DCR Sec (Ω) MAX	Isolation Voltage (Vrms) MIN	Package Schematic	Primary Pins
15T-1221HC	1:1	1.20	25	0.50	0.70	0.70	1500	H/C THT	1-2

15T - SERIES

T3/DS3/E3/STS-1 TRANSFORMERS Designed for T3, DS3 and STS-1 Interfaces

MARKINGS AND DIMENSIONS

Dimensions: inches/mm unless otherwise specified, all tolerances are $\pm .010/\pm 0.25$

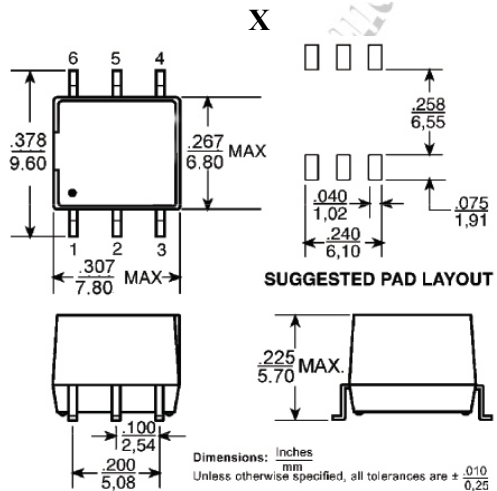
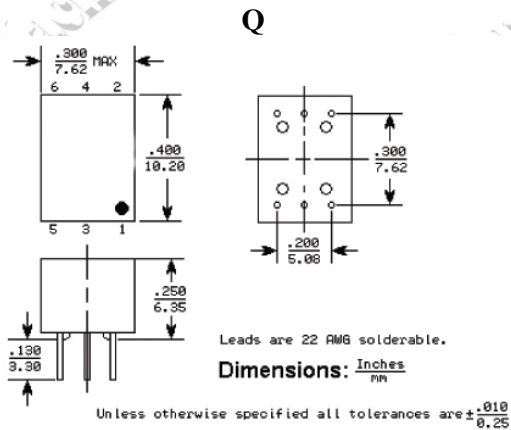
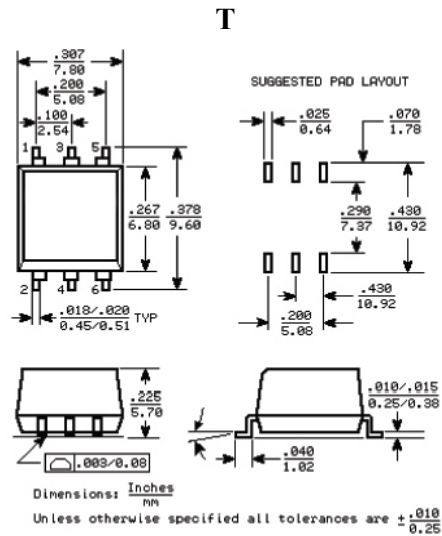
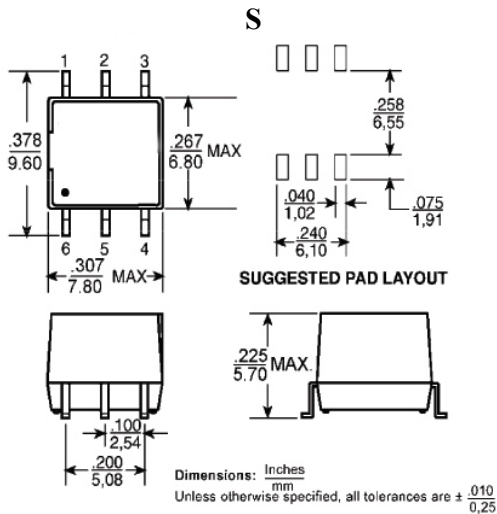
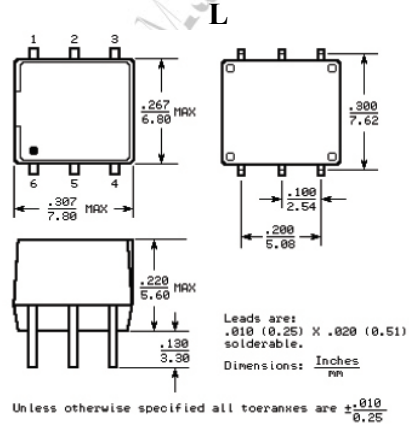
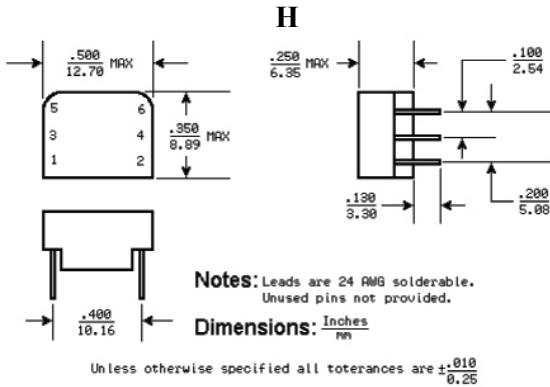

15T - SERIES

T3/DS3/E3/STS-1 TRANSFORMERS Designed for T3, DS3 and STS-1 Interfaces

Schematics

